



Pizza Warmer

Model DW-CN-0457

Item 20427

Instruction Manual



Revised - 06/18/2024



Toll Free: 1-800-465-0234
Fax: 905-607-0234
Email: service@omcan.com
www.omcan.com



Table of Contents

Model DW-CN-0457

Section	Page
General Information -----	3 - 4
Safety and Warranty -----	4 - 5
Technical Specifications -----	6
Assembly Instruction -----	6 - 8
Installation -----	9
Function and Operation -----	9
Maintenance -----	9 - 10
Troubleshooting -----	10
Parts Breakdown -----	11 - 12
Electrical Schematics -----	13
Notes -----	14
Warranty Registration -----	15



General Information

Omcan Manufacturing and Distributing Company Inc., Food Machinery of America, Inc. dba Omcan and Omcan Inc. are not responsible for any harm or injury caused due to any person's improper or negligent use of this equipment. The product shall only be operated by someone over the age of 18, of sound mind, and not under the influence of any drugs or alcohol, who has been trained in the correct operation of this machine, and is wearing authorized, proper safety clothing. Any modification to the machine voids any warranty, and may cause harm to individuals using the machine or in the vicinity of the machine while in operation.

CHECK PACKAGE UPON ARRIVAL

Upon receipt of an Omcan shipment please inspect for external damage. If no damage is evident on the external packaging, open carton to ensure all ordered items are within the box, and there is no concealed damage to the machine. If the package has suffered rough handling, bumps or damage (visible or concealed), please note it on the bill of lading before accepting the delivery and contact Omcan within 24 hours, so we may initiate a claim with the carrier. A detailed report on the extent of the damage caused to the machine must be filled out within three days, from the delivery date shown in the shipping documents. Omcan has no recourse for damaged products that were shipped collect or third party.

Before operating any equipment, always read and familiarize yourself with all operation and safety instructions.

Omcan would like to thank you for purchasing this machine. It's of the utmost importance to save these instructions for future reference. Also save the original box and packaging for shipping the equipment if servicing or returning of the machine is required.

Omcan Fabrication et distribution Compagnie Limité et Food Machinery d'Amérique, dba Omcan et Omcan Inc. ne sont pas responsables de tout dommage ou blessure causé du fait que toute personne ait utilisé cet équipement de façon irrégulière. Le produit ne doit être exploité que par quelqu'un de plus de 18 ans, sain d'esprit, et pas sous l'influence d'une drogue ou d'alcool, qui a été formé pour utiliser cette machine correctement, et est vêtu de vêtements de sécurité appropriés. Toute modification de la machine annule toute garantie, et peut causer un préjudice à des personnes utilisant la machine ou des personnes à proximité de la machine pendant son fonctionnement.

VÉRIFIEZ LE COLIS DÈS RÉCEPTION

Dès réception d'une expédition d'Omcan veuillez inspecter pour dommages externes. Si aucun dommage n'est visible sur l'emballage externe, ouvrez le carton afin de s'assurer que tous les éléments commandés sont dans la boîte, et il n'y a aucun dommage dissimulé à la machine. Si le colis n'a subi aucune mauvaises manipulations, de bosses ou de dommages (visible ou cachée), notez-le sur le bond de livraison avant d'accepter la livraison et contactez Omcan dans les 24 heures qui suivent, pour que nous puissions engager une réclamation auprès du transporteur. Un rapport détaillé sur l'étendue des dommages causés à la machine doit être rempli dans un délai de trois jours, à compter de la date de livraison indiquée dans les documents d'expédition. Omcan n'a aucun droit de recours pour les produits endommagés qui ont été expédiés ou cueillis par un tiers transporteur.

Avant d'utiliser n'importe quel équipement, toujours lire et vous familiariser avec toutes les opérations et les

General Information

consignes de sécurité.

Omcan voudrais vous remercier d'avoir choisi cette machine. Il est primordial de conserver ces instructions pour une référence ultérieure. Également conservez la boîte originale et l'emballage pour l'expédition de l'équipement si l'entretien ou le retour de la machine est nécessaire.

Omcan Empresa De Fabricacion Y Distribucion Inc. Y Maquinaria De Alimentos De America, Inc. dba Omcan y Omcan Inc. no son responsables de ningun daño o perjuicio causado por cualquier persona inadecuada o el uso descuidado de este equipo. El producto solo podra ser operado por una persona mayor de 18 años, en su sano juicio y no bajo alguna influencia de droga o alcohol, y que este ha sido entrenado en el correcto funcionamiento de esta máquina, y ésta usando ropa apropiada y autorizada. Cualquier modificación a la máquina anula la garantía y puede causar daños a las personas usando la máquina mientras esta en el funcionamiento.

REVISE EL PAQUETE A SU LLEGADA

Tras la recepcion de un envio Omcan favor inspeccionar daños externos. Si no hay daños evidentes en el empaque exterior, Habra el carton para asegurarse que todos los articulos solicitados estén dentro de la caja y no encuentre daños ocultos en la máquina. Si el paquete ha sufrido un manejo de poco cuidado, golpes o daños (visible o oculto) por favor anote en la factura antes de aceptar la entrega y contacte Omcan dentro de las 24 horas, de modo que podamos iniciar una reclamación con la compañía. Un informe detallado sobre los daños causados a la máquina debe ser llenado en el plazo de tres días, desde la fecha de entrega que se muestra en los documentos de envío. Omcan no tiene ningun recurso por productos dañados que se enviaron a recoger por terceros.

Antes de utilizar cualquier equipo, siempre lea y familiarizarse con todas las instrucciones de funcionamiento y seguridad.

Omcan le gustaría darle las gracias por la compra de esta máquina. Es de la mayor importancia para salvar estas instrucciones para futuras consultas. Además, guarda la caja original y el embalaje para el envío del equipo si servicio técnico o devolución de la máquina que se requiere.

Safety and Warranty

WARNING

1. If the supply cord is damaged it must be replaced by Omcan, or a qualified service agent in order to avoid any electrical hazards.
2. This appliance shall not be cleaned with any type of liquid pressurized cleaning equipment.
3. This appliance is not intended for use by persons (including children) with reduced physical, sensory or mental capabilities, or lack of experience and knowledge, unless they have been given specific instruction with proper supervision concerning the use of this appliance.

Safety and Warranty

4. Under no circumstances should any children be allowed to operate this equipment unless properly supervised.
5. This equipment comes with a properly grounded power cord. All power receptacles should be installed with a properly installed grounded circuit.

SAFE OPERATION NOTICE

- All operators must strictly observe and follow local state or provincial electrical safety codes and guidelines.
- This unit must be used by qualified and trained personnel at all times. Staff should be instructed on proper daily operation and maintenance prior to usage.
- Before operating machine, ensure that all covers, doors and moving components are installed properly and working prior to usage. This will ensure unit is in safe operating order and provide years of long lasting service.

RESIDENTIAL USERS: vendor assumes no liability for parts or labor coverage for component failure or other damages resulting from installation in non-commercial or residential applications. The right is reserved to deny shipment for residential usage; if this occurs, you will be notified as soon as possible.

1 YEAR PARTS AND LABOUR BENCH WARRANTY

Within the warranty period, contact Omcan Inc. at 1-800-465-0234 to schedule a drop off to either an Omcan authorized service depot in the area, or to an Omcan Service warehouse to repair the equipment.

Unauthorized maintenance will void the warranty. Warranty covers electrical and part failures, not improper use.

Please see <https://omcan.com/disclaimer> for complete info.

WARNING:

The packaging components are classified as normal solid urban waste and can therefore be disposed of without difficulty.

In any case, for suitable recycling, we suggest disposing of the products separately (differentiated waste) according to the current norms.

DO NOT DISCARD ANY PACKAGING MATERIALS IN THE ENVIRONMENT!

Technical Specifications

This pizza warmer is mainly utilized in commercial spaces such as fast-food restaurants, convenience stores along with self-service restaurants and supermarkets.

FEATURES OF OUR PRODUCTS

- The unit comes with two florescent lighting fixtures which increases the view ability of the product being displayed.
- The unit also features adjustable humidity and heat controls which allow greater flexibility to improve overall product freshness and consistency.
- The unit thermostat control allows for even heat during the warming period on all food surfaces.

TECHNICAL SPECIFICATIONS

Model	DW-CN-0457
Item Number	20427
Power	1380 W
Temperature	30 - 70°C / 86 - 158°F
Electrical	110-120V / 60Hz / 1
Maximum Pizza Size (Diameter)	18" / 457mm
Weight	99 lbs. / 44.9 kgs.
Packaging Weight	148 lbs. / 67.1 kgs.
Dimensions (DWH)	23.6" x 23.6" x 27.6" / 600 x 600 x 700mm
Packaging Dimensions	18.9" x 15.7" x 15" / 480 x 400 x 380mm

Assembly Instructions

INSTALLING THE GLASS SIDES

1. Unscrew the glass holder brackets near the bottom of the sides of the unit until they are all loose.
2. Align one of the glass sides with the unit, putting the top of the glass into the channel located on the top of the unit.
3. Turn the bottom brackets upward and tighten, ensure that the bracket firmly holds the glass.
4. Follow steps 2 and 3 for the other sides.

Assembly Instructions

INSTALLING THE DOORS



1. Lower left side door hinge assembly with two gaskets as above. Install the door hinge to the lower left side of the glass door, paying particular attention to the white colored gasket. The gasket must be placed on the screw side of the door hinge between the glass and the door hinge itself. The other gasket is to be placed on the outside of the door hinge in between (in the same manner). Please note do not over tighten the screws as this can lead to damaging the glass door.



2. Remove any plastic protective film prior to assembling. Place the complete secured lower left side door and hinge assembly into the lower left side of the cabinet.



3. Place the left side top door hinge assembly into the upper frame left hole slot and proceed to slide and insert the complete glass door into the top door hinge. Please note the arrow direction in the figure above. Once in place slide supplied gaskets in between door hinge assembly and glass door making sure white gasket is in behind door hinge with screws and tighten loosely.

Assembly Instructions



4. Paying specific attention to the door gaps, adjust accordingly leaving the same even space around the complete perimeter of the door. During this process tighten and loosen the screws till the door is plumb and level making sure it opens and closes freely without obstruction. Review the figure above.



5. Installing the magnet door catch/release along with the separate magnet interlock catch is similar to the door hinges; only difference is they do not swivel. They must however mate up and align facing the magnetic door latch, and separate magnet door interlock switch. It is located on the top inside right side of the display warmer case. Please note the white gaskets should always be facing the screw side of the door catches. Again align door latch and lock into place making sure it aligns to the push type locking hardware. Next place the interlock latch with the provided miniature magnet (black rectangular magnet) and place it into the slot of the latch and glass door. Tighten screws, paying attention not to over tighten. The door should now be able to be opened and close by simply pressing the top right hand latch and the magnet should release allowing the door to open and thus stop the rotating display. Closing is just the reverse and thus will magnetically lock the door and start the rotation of the display.



6. The above is a final photo of what your Pizza Display Warmer will look like. If necessary you can still adjust the door gaps as required by loosening the screws and re-adjusting the glass accordingly.

Installation

ACCESSORIES INCLUDED:

No:	Item	Quantity	Unit
1	Tempered Glass	4	pcs
2	Turn Basket Display	1	sets
3	Water Pan	1	pcs

ELECTRICAL INSTALLATION:

When first installed ensure proper power requirements are met. A standard 15A/110-120V receptacle with ground must be utilized.

Function and Operation

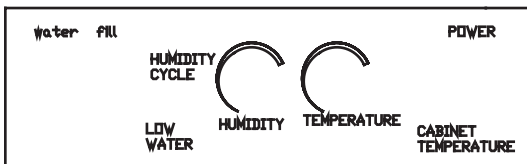

- Water tray reservoir must be filled to the correct amount until low water level indicator turns off.
- Main power switch supplies power to cabinet temperature heat and humidity controls along with interior lighting. Upon closing front access door rotating product display will begin to turn for product display.
- Humidity control dial is used to increase or decrease the level of humidity in the cabinet for specific product being displayed.
- Temperature control dial is used to increase or decrease cabinet heat level. Once dialed and set the unit will monitor and control constant temperature within the cabinet.

Maintenance

- Daily maintenance should be carried out with all power to the unit in the off position, and electrical cord unplugged.
- The unit must be given appropriate time to cool down before cleaning can commence. Cleaning should be carried out by means of food grade cleaning solutions via a soft or damp cloth. Do not utilize any type of pressurized water equipment.
- Regular inspection on the outside and internal cabinet along with the power cord should be observed and carried out on a regular basis to isolate and or observe any unforeseen failure or safety concern.

Maintenance

Warning: cleaning outside and internal cabinet must be made with power off at all times.

Troubleshooting

COMMON TROUBLE AND SOLUTION

Fault	Reason(s)	Solution(s)
No lighting in interior cabinet.	No power.	Inspect power source.
	Florescent lamps failure.	Replace florescent tubes.
Rotating display has stopped.	Motor damage.	Replace motor.
	Front door not completely closed.	Close front door/check magnetic door sensor.
Interior cabinet heat is not warming up.	Thermostat off.	Dial in temperature.
	Thermostat or heater coil failure.	Contact service agent required for possible replacement of heater coil or thermostat.

Parts Breakdown

Model DW-CN-0457 20427

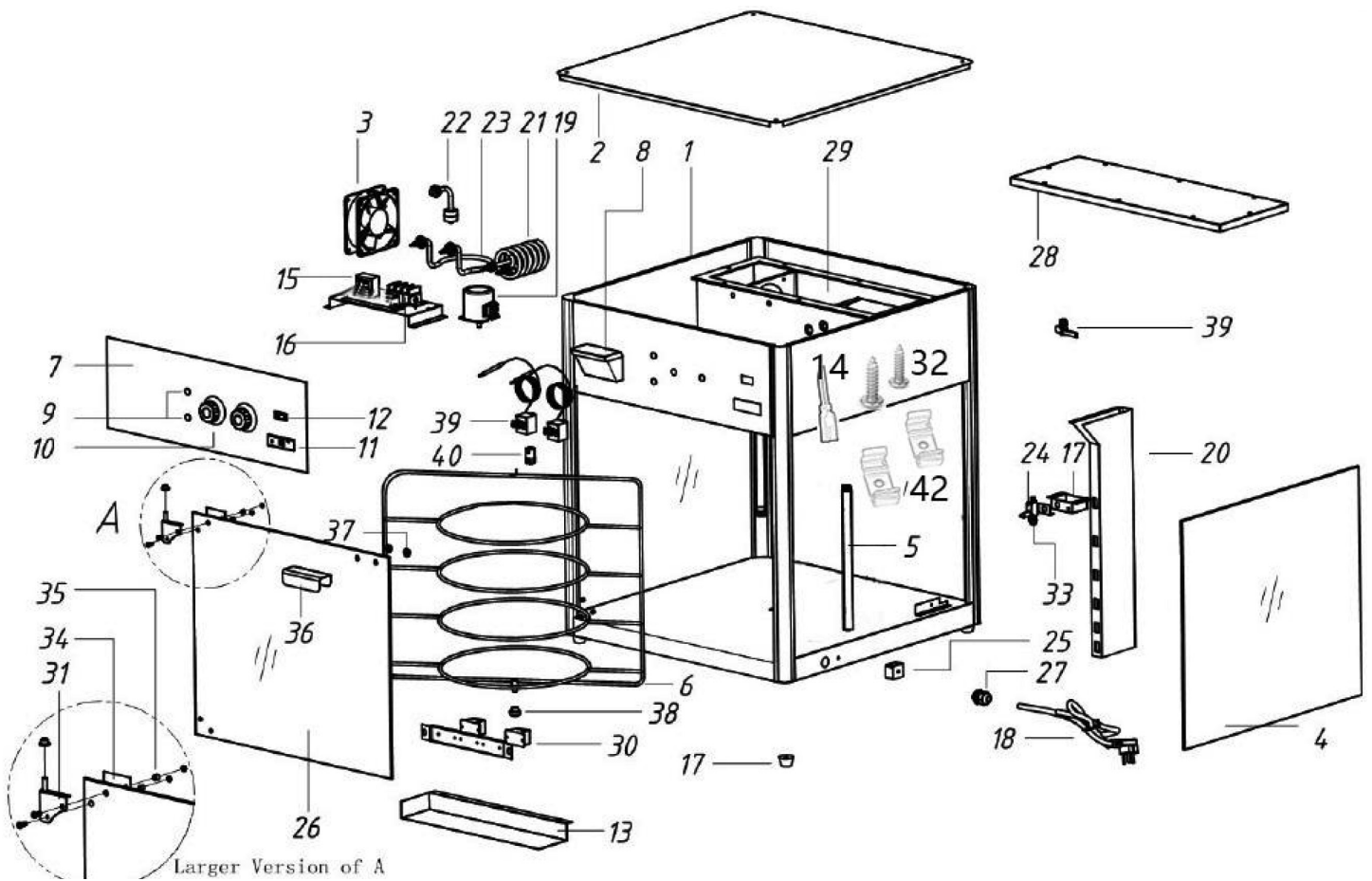

Parts Breakdown

Model DW-CN-0457 20427

Item No.	Description	Position	Item No.	Description	Position	Item No.	Description	Position
25165	Hard Surface for 20427	1	37510	Transformer for 20427	15	37516	Heater Box Assembly for 20427	29
25166	Top Cover for 20427	2	37511	Terminal Block for 20427	16	37496	Relay for 20427	30
25178	Draught Fan for 20427	3	25167	Rubber Feet for 20427	17	23508	Door Magnet Hardware for 20427	31
23914	Left/Right/Back Side Glass for 20427	4	24746	Plug and Power Cord for 20427	18	AQ893	LED Tube Holder's Screw for 20427	32
AQ891	LED Tube for 20427	5	25180	Motor for 20427	19	70406	Magnet for 20427	33
25169	Rotary Shelf for 20427	6	25176	Wind-Guiding Path for 20427	20	70407	Door Hinges B for 20427	34
25175	PVC Board for 20427	7	25179	Ambient Heater Coil for 20427	21	70408	Door Hinges Mat for 20427	35
25173	Infall Box for 20427	8	25177	Float for 20427	22	70409	Door Handle for 20427	36
25171	Indicator Light for 20427	9	23507	Humidity Heater Coil for 20427	23	70410	Rubber Gasket for 20427	37
25172	Temperature Controller for 20427	10	70404	Microswitch for 20427	24	70411	Bearing for 20427	38
25170	Temperature Indicator for 20427	11	37514	5 Hole Terminal Block for 20427	25	70412	Thermostat for 20427	39
25174	Boat Shaped Switch for 20427	12	25168	Glass Door for 20427	26	70413	Rotating Shaft Sleeve for 20427	40
70403	Waterproof Board for 20427	13	70405	Power Cord Bushings for 20427	27	AC134	Drain Valve for 20427	41
AQ892	LED Tube Plug for 20427	14	37515	Heater Box Cover for 20427	28	AQ894	LED Tube Holder for 20427	42

Electrical Schematics

Model DW-CN-0457 20427

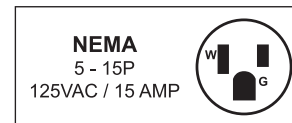
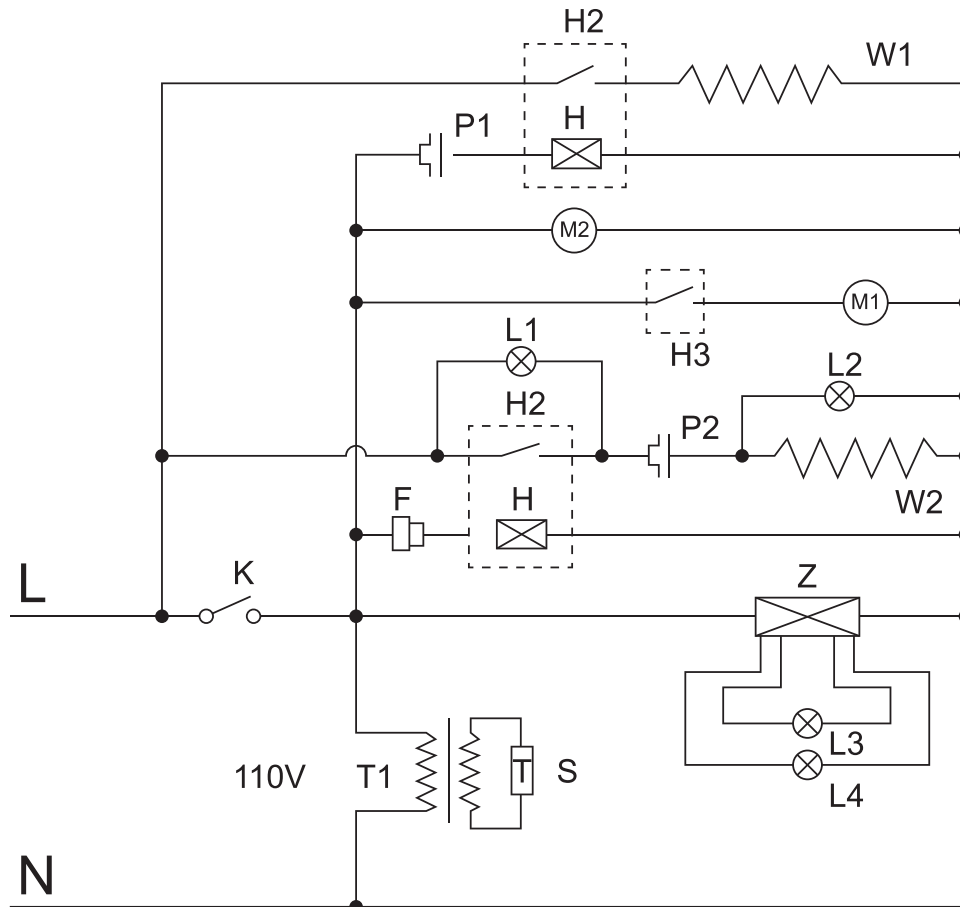

- | | |
|-------------------------------------|--------------------------|
| K - Power Switch | L2 - Heating Light |
| H1 - Relay | L3 - Flourescent Tube |
| H2 - Relay | L4 - Flourescent Tube |
| W1 - Heater | H3 - Micro Switch |
| W2 - Heater | T1 - Temperature Display |
| P1 - Temperature Controller | S - Transformer |
| P2 - Temperature Controller | Z - Ballast |
| L1 - Water Shortage Indicator Light | F - Level Switch |



Warranty Registration

Thank you for purchasing an Omcan product. To register your warranty for this product, complete the information below, tear off the card at the perforation and then send to the address specified below. You can also register online by visiting:

Merci d'avoir acheté un produit Omcan. Pour enregistrer votre garantie pour ce produit, complétez les informations ci-dessous, détachez la carte au niveau de la perforation, puis l'envoyer à l'adresse spécifiée ci-dessous. Vous pouvez également vous inscrire en ligne en visitant:

Gracias por comprar un producto Omcan usted. Para registrar su garantía para este producto, complete la información a continuación, cortar la tarjeta en la perforación y luego enviarlo a la dirección indicada a continuación. También puede registrarse en línea en:

<https://omcan.com/warranty-registration/>

For mailing in Canada

Pour postale au Canada

Por correo en Canadá

For mailing in the US

Pour diffusion aux États-Unis

Por correo en los EE.UU.

OMCAN

PRODUCT WARRANTY REGISTRATION

3115 Pepper Mill Court,
Mississauga, Ontario
Canada, L5L 4X5

OMCAN

PRODUCT WARRANTY REGISTRATION

4450 Witmer Industrial Estates, Unit 4,
Niagara Falls, New York
USA, 14305

or email to: service@omcan.com



Purchaser's Information

Name: _____

Company Name: _____

Address: _____

Telephone: _____

City: _____ Province or State: _____ Postal or Zip: _____

Email Address: _____

Country: _____

Type of Company:

Restaurant Bakery Deli

Butcher Supermarket Caterer

Institution (*specify*): _____

Other (*specify*): _____

Dealer from which Purchased: _____

Dealer City: _____ Dealer Province or State: _____

Invoice: _____

Model Name: _____ Model Number: _____

Serial Number: _____

Machine Description: _____

Date of Purchase (MM/DD/YYYY): _____

Date of Installation (MM/DD/YYYY): _____

Would you like to extend the warranty? Yes No

Thank you for choosing Omcan | Merci d'avoir choisi Omcan | Gracias por elegir Omcan



Since 1951 Omcan has grown to become a leading distributor of equipment and supplies to the North American food service industry. Our success over these many years can be attributed to our commitment to strengthen and develop new and existing relationships with our valued customers and manufacturers. Today with partners in North America, Europe, Asia and South America, we continually work to improve and grow the company. We strive to offer customers exceptional value through our qualified local sales and service representatives who provide convenient access to over 6,500 globally sourced products.

Depuis 1951 Omcan a grandi pour devenir un des "leaders" de la distribution des équipements et matériel pour l'industrie des services alimentaires en Amérique du Nord. Notre succès au cours de ces nombreuses années peut être attribué à notre engagement à renforcer et à développer de nouvelles et existantes relations avec nos clients et les fabricants de valeur. Aujourd'hui avec des partenaires en Amérique du Nord, Europe, Asie et Amérique du Sud, nous travaillons continuellement à améliorer et développer l'entreprise. Nous nous efforçons d'offrir à nos clients une valeur exceptionnelle grâce à nos ventes locales qualifiées et des représentants de service qui offrent un accès facile à plus de 6500 produits provenant du monde entier.

Desde 1951 Omcan ha crecido hasta convertirse en un líder en la distribución de equipos y suministros de alimentos en América del Norte industria de servicios. Nuestro éxito en estos años se puede atribuir a nuestro compromiso de fortalecer y desarrollar nuevas relaciones existentes con nuestros valiosos clientes y fabricantes. Hoy con socios de América del Norte, Europa, Asia y América del Sur, que trabajan continuamente para mejorar y crecer la empresa. Nos esforzamos por ofrecer a nuestros clientes valor excepcional a través de nuestro local de ventas y representantes de los servicios que proporcionan un fácil acceso a más de 6,500 productos con origen a nivel mundial.

